

REVISION C

DO NOT SCALE FROM THIS PRINT

NOTES:

1. Ⓢ REPRESENTS A CRITICAL DIMENSION.
2. PARTS TO BE PACKAGED IN TUBE.
3. SPECIAL GAGE AT-2019-049 TO BE USED FOR DIMENSIONS C1, C2, C4, C5 C6, C7 CHECK.

DESIGNED & DIMENSIONED IN MILLIMETERS[INCHES]

PCIE-XXX-02-X-D-RA

No OF POSITIONS
-036, -064, -098, -164 (DOUBLE ROW)

LEAD STYLE
-02: 1.57[.062"] THICK CARD

PLATING SPECIFICATION
(VALUES GIVEN ARE IN MICRO INCHES)
-S: 30u" MIN Au/50u" Ni IN CONTACT, MATING TIN ON TAIL
-F: 3u" MIN Au/50u" Ni IN CONTACT, MATING TIN ON TAIL

OPTION
-RA: RIGHT ANGLE

ROW SPECIFICATION
-D: DOUBLE ROW

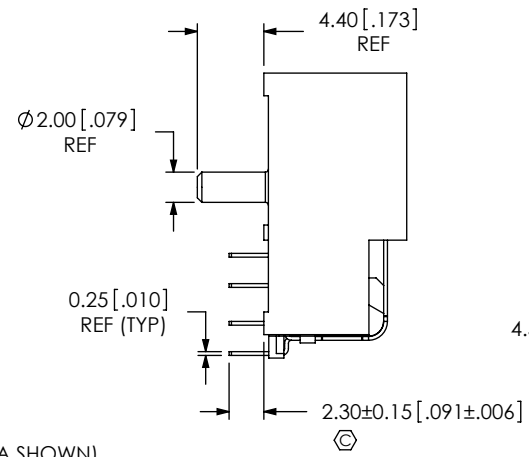
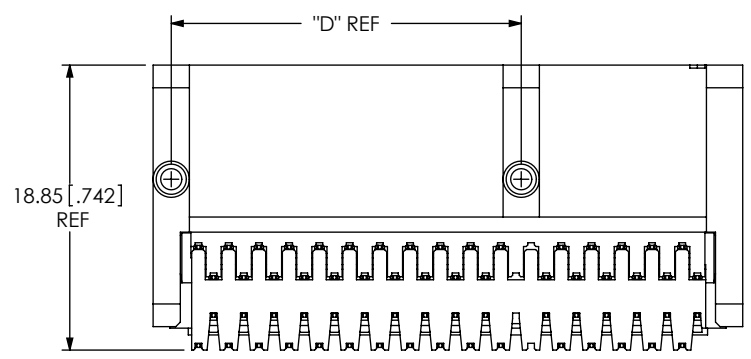
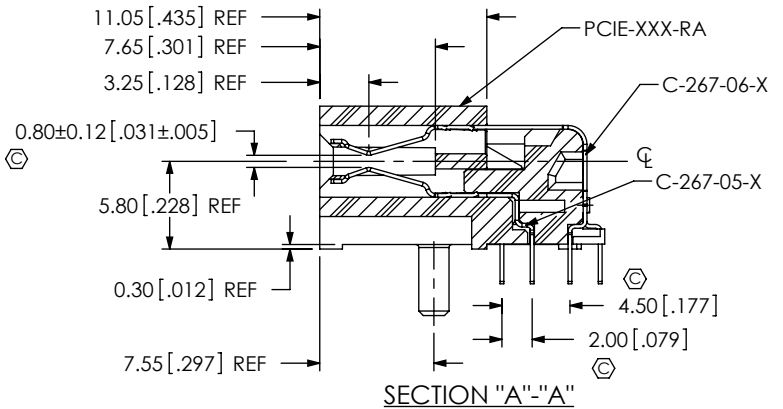
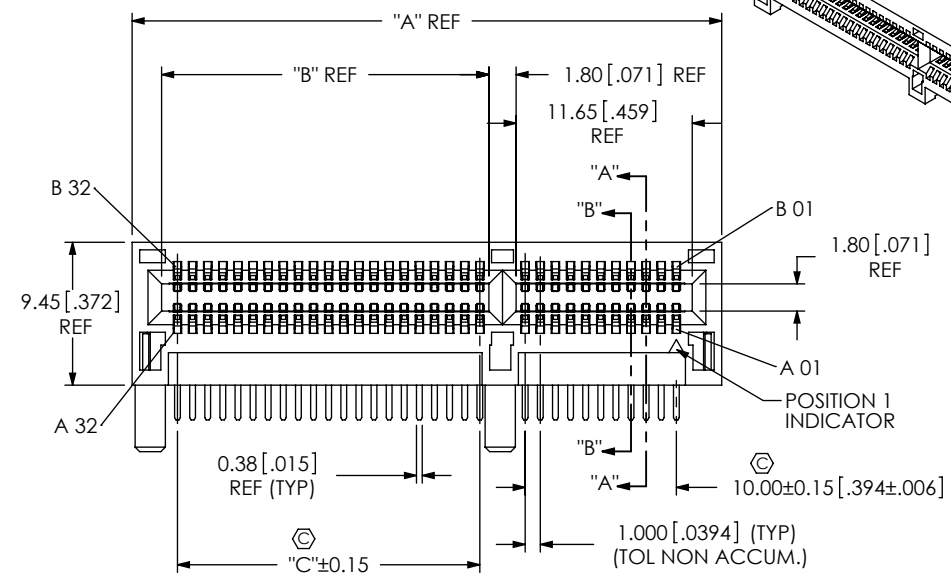
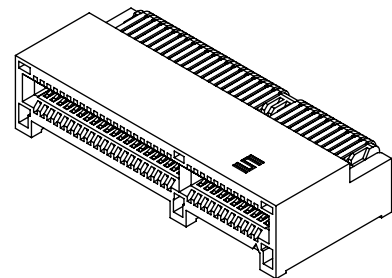

FIG. 1
(PCIE-064-02-X-D-RA SHOWN)

SECTION "B"- "B"
(SAME AS SECTION "A"- "A", EXCEPT AS SHOWN)

No. OF POS	"A"	"B"	"C"	"D"
-036	25.00 [0.984]	7.65 [0.301]	6.00 [0.236]	9.150 [0.3602]
-064	39.00 [1.535]	21.65 [0.852]	20.00 [0.787]	23.150 [0.9114]
-098	56.00 [2.205]	38.65 [1.522]	37.00 [1.457]	40.150 [1.5807]
-164	89.00 [3.504]	71.65 [2.821]	70.00 [2.756]	73.150 [2.8799]

UNLESS OTHERWISE SPECIFIED, DIMENSIONS ARE IN MILLIMETERS[INCHES]. TOLERANCES ARE:
DECIMALS ANGLES
X.X: ±0.3 [0.1]
X.XX: ±0.13 [0.05]
X.XXX: ±0.051 [0.020]

PROPRIETARY NOTE
THIS DOCUMENT CONTAINS CONFIDENTIAL AND PROPRIETARY INFORMATION AND ALL DESIGN, MANUFACTURING, REPRODUCTION, USE, PATENT RIGHTS AND SALES RIGHTS ARE EXPRESSLY RESERVED BY SAMTEC, INC. THIS DOCUMENT SHALL NOT BE DISCLOSED, IN WHOLE OR PART, TO ANY UNAUTHORIZED PERSON OR ENTITY NOR REPRODUCED, TRANSFERRED OR INCORPORATED IN ANY OTHER PROJECT IN ANY MANNER WITHOUT THE EXPRESS WRITTEN CONSENT OF SAMTEC, INC.

MATERIAL: DO NOT SCALE DRAWING SHEET SCALE: 2:1
INSULATOR: LCP, COLOR: BLACK
CONTACT: PHOS BRONZE

samtec
520 PARK EAST BLVD. NEW ALBANY, IN 47150
PHONE: 812-944-6733 FAX: 812-948-5047
e-Mail: info@SAMTEC.com code 55322

DESCRIPTION: PCI EXPRESS RIGHT ANGLE ASSEMBLY
DWG. NO.: PCIE-XXX-02-X-D-RA

BY: ROY LUO 10/21/2009 **SHEET 1 OF 3**

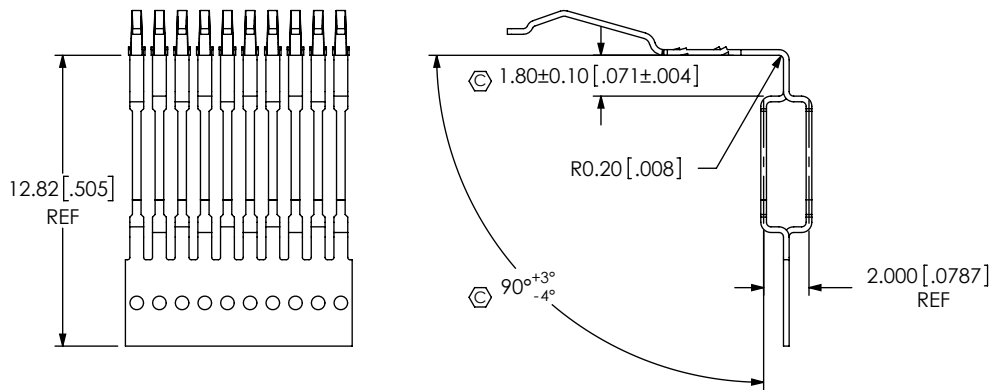

IN-PROCESS 1
(FORM CONTACT C-267-05-X)

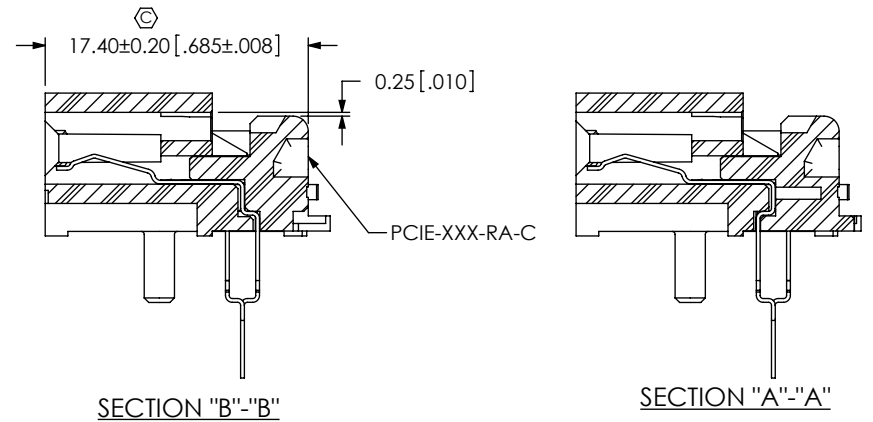

IN-PROCESS 3
(FILL PCIE-XXX-RA-C)

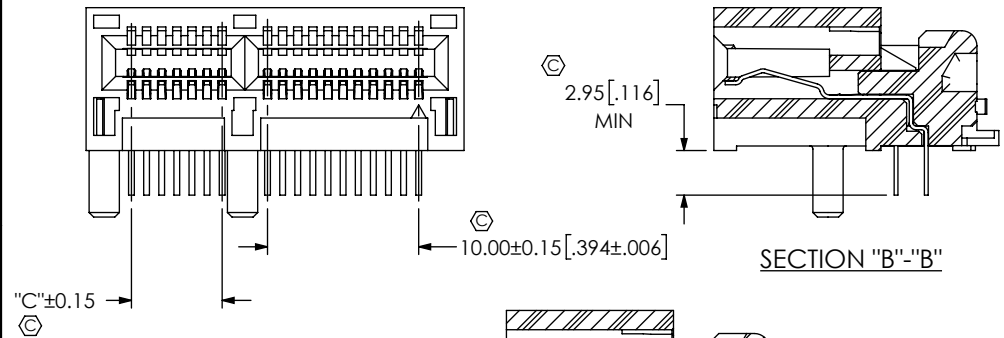

IN-PROCESS 4
(CUTOFF OF CARRIER)

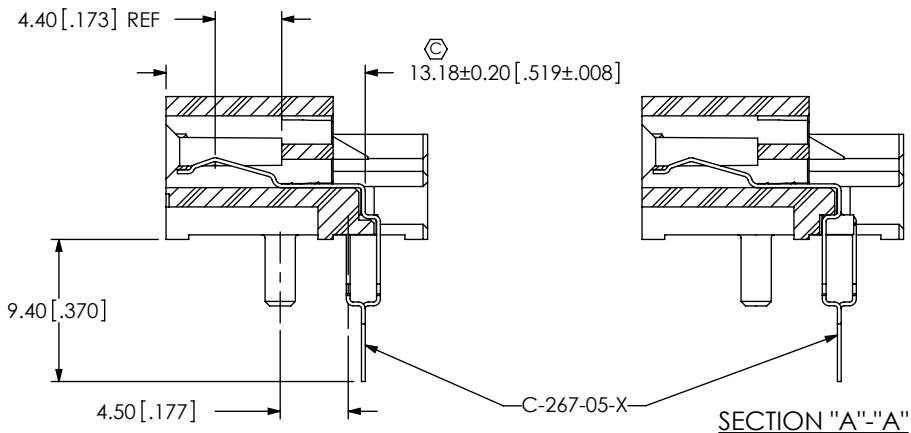

SECTION "B"-"B"

SECTION "A"-"A"

IN-PROCESS 2
(FILL BOTTOM ROW)

PROPRIETARY NOTE
THIS DOCUMENT CONTAINS CONFIDENTIAL AND PROPRIETARY INFORMATION AND ALL DESIGN, MANUFACTURING, REPRODUCTION, USE, PATENT RIGHTS AND SALES RIGHTS ARE EXPRESSLY RESERVED BY SAMTEC, INC. THIS DOCUMENT SHALL NOT BE DISCLOSED, IN WHOLE OR IN PART, TO ANY UNAUTHORIZED PERSON OR ENTITY NOR REPRODUCED, TRANSFERRED OR INCORPORATED IN ANY OTHER PROJECT IN ANY MANNER WITHOUT THE EXPRESS WRITTEN CONSENT OF SAMTEC, INC.

DO NOT SCALE DRAWING

SHEET SCALE: 2:1

samtec

520 PARK EAST BLVD, NEW ALBANY, IN 47150
PHONE: 812-944-6733 FAX: 812-948-5047
e-Mail: info@SAMTEC.com code 55322

DESCRIPTION:
PCI EXPRESS RIGHT ANGLE ASSEMBLY

DWG. NO.
PCI-E-XXX-02-X-D-RA

BY: ROY LUO 10/21/2009 SHEET 2 OF 3

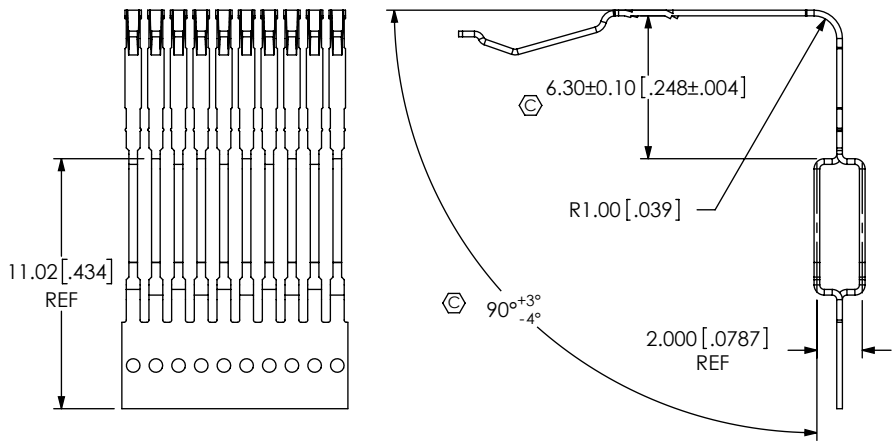

IN-PROCESS 5
(FORM CONTACT C-267-06-X)

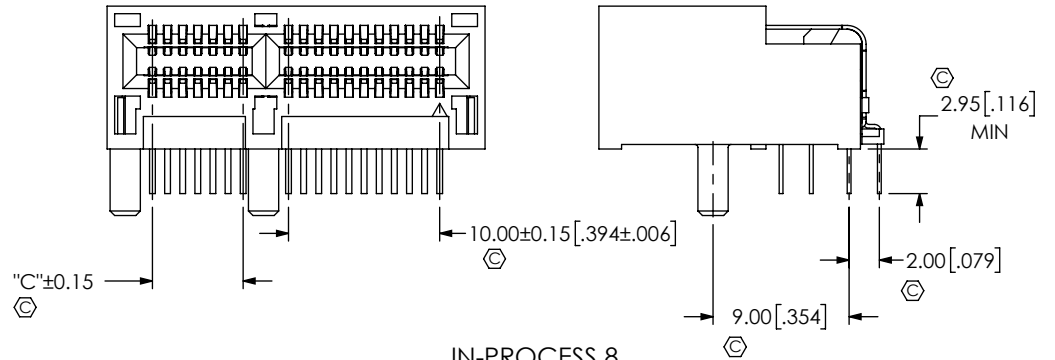

IN-PROCESS 8
(CUT OFF TOP
CONTACT CARRIER)

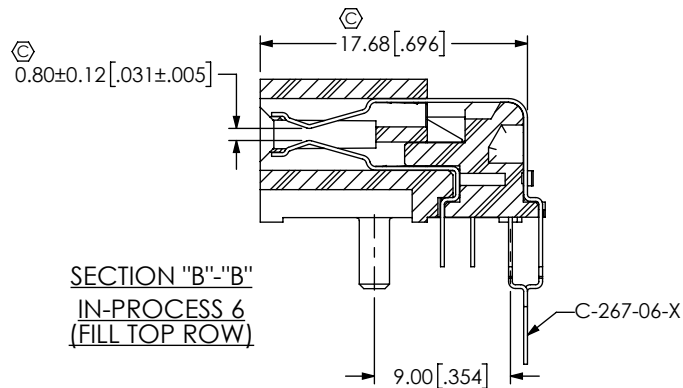

SECTION "B"-"B"
IN-PROCESS 6
(FILL TOP ROW)

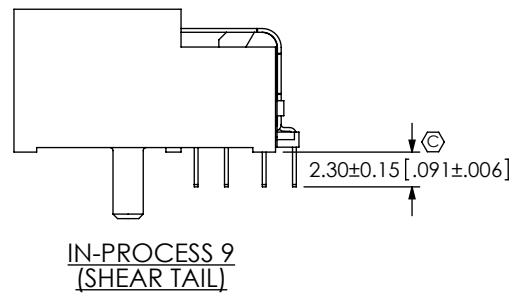

IN-PROCESS 9
(SHEAR TAIL)

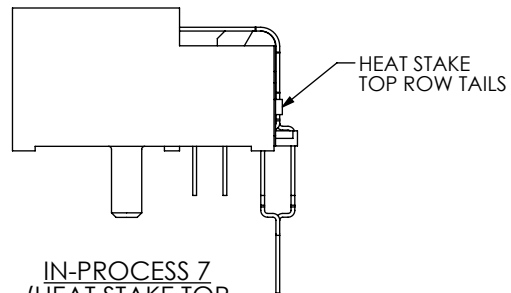

IN-PROCESS 7
(HEAT STAKE TOP
ROW CONTACTS)

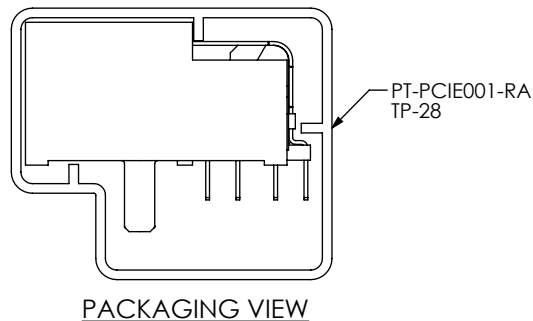

PACKAGING VIEW

c:\enterprisevault\DWG\MISC\MKTG\PCIE-XXX-02-X-D-RA-MKT.SLDDRW

PROPRIETARY NOTE
THIS DOCUMENT CONTAINS CONFIDENTIAL AND PROPRIETARY INFORMATION AND ALL DESIGN, MANUFACTURING, REPRODUCTION, USE, PATENT RIGHTS AND SALES RIGHTS ARE EXPRESSLY RESERVED BY SAMTEC, INC. THIS DOCUMENT SHALL NOT BE DISCLOSED, IN WHOLE OR PART, TO ANY UNAUTHORIZED PERSON OR ENTITY NOR REPRODUCED, TRANSFERRED OR INCORPORATED IN ANY OTHER PROJECT IN ANY MANNER WITHOUT THE EXPRESS WRITTEN CONSENT OF SAMTEC, INC.

DO NOT SCALE DRAWING

SHEET SCALE: 2:1



520 PARK EAST BLVD, NEW ALBANY, IN 47150
PHONE: 812-944-6733 FAX: 812-948-5047
e-Mail info@SAMTEC.com code 55322

DESCRIPTION:
PCI EXPRESS RIGHT ANGLE ASSEMBLY

DWG. NO. **PCIE-XXX-02-X-D-RA**

BY: ROY LUO 10/21/2009 SHEET 3 OF 3