

Bipolar Stepper and High-Current DC Motor Driver

FEATURES AND BENEFITS

- 40 V output rating
- 3.2 A DC motor driver
- 1.6 A bipolar stepper driver
- Synchronous rectification
- Internal undervoltage lockout (UVLO)
- Thermal shutdown circuitry
- Crossover-current protection
- Very thin profile QFN package
- Overcurrent protection
- Low-power sleep mode
- 3.3 and 5 V compatible logic supply

PACKAGE:

36-pin QFN with exposed thermal pad
0.90 mm nominal height (suffix EV)

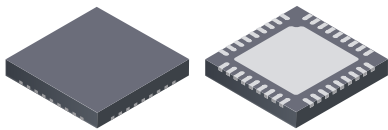

Not to scale

DESCRIPTION

The A5989 is designed to operate at voltages up to 40 V while driving one bipolar stepper motor at currents up to 1.6 A, and one DC motor at currents up to 3.2 A. The A5989 includes a fixed off-time pulse-width modulation (PWM) regulator for current control. The stepper motor driver features dual 2-bit nonlinear DACs (digital-to-analog converters) that enable control in full, half, and quarter steps. The DC motor is controlled using standard PHASE and ENABLE signals. Fast or slow current decay is selected via the MODE pin. The PWM current regulator uses the Allegro™ patented mixed decay mode for reduced audible motor noise, increased step accuracy, and reduced power dissipation.

Internal synchronous rectification control circuitry is provided to improve power dissipation during PWM operation.

Protection features include thermal shutdown with hysteresis, undervoltage lockout (UVLO), crossover-current and short-circuit protection. Special power-up sequencing is not required.

The A5989 is supplied in a leadless 6 mm × 6 mm × 0.9 mm, 36-pin QFN package with exposed power tab for enhanced thermal performance. The package is lead (Pb) free, with 100% matte-tin leadframe plating.

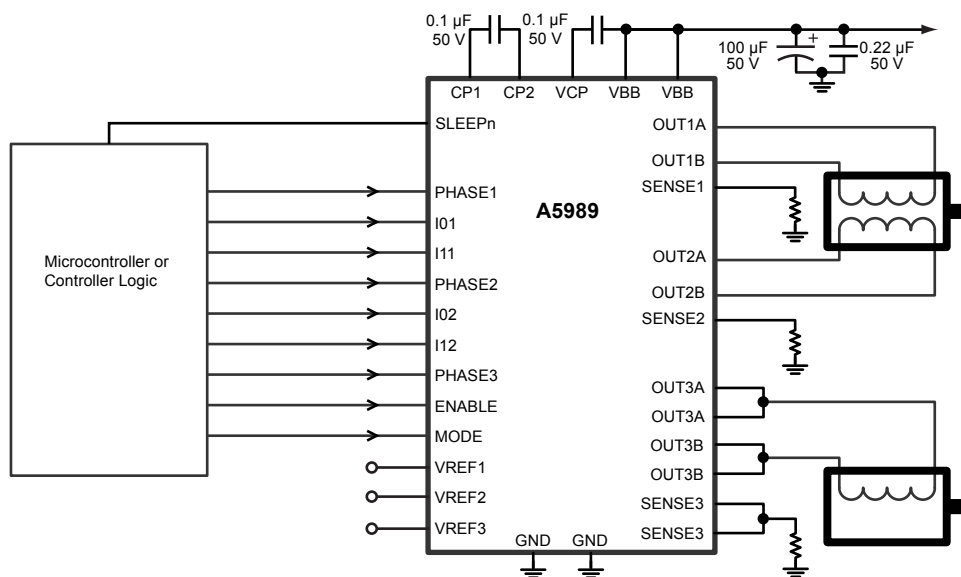

Figure 1: Typical Application Circuit

SELECTION GUIDE

Part Number	Packing
A5989GEVTR-T	1500 pieces per reel



ABSOLUTE MAXIMUM RATINGS

Characteristic	Symbol	Notes	Rating	Units
Load Supply Voltage	V_{BB}		-0.5 to 40	V
Output Current ^[1]	I_{OUT}	Stepper motor driver, continuous	1.6	A
		DC motor driver, continuous	3.2	A
Logic Input Voltage Range	V_{IN}		-0.3 to 7	V
SENSEx Pin Voltage	V_{SENSEX}		0.5	V
		Pulsed $t_w < 1 \mu s$	2.5	V
VREFx Pin Voltage	V_{REFx}		2.5	V
Operating Temperature Range	T_A	Range G	-40 to 105	°C
Junction Temperature	$T_J(\max)$		150	°C
Storage Temperature Range	T_{stg}		-55 to 150	°C

^[1] May be limited by duty cycle, ambient temperature, and heat sinking. Under any set of conditions, do not exceed the specified current rating or a Junction Temperature of 150°C.

THERMAL CHARACTERISTICS: May require derating at maximum conditions

Characteristic	Symbol	Test Conditions	Min.	Units
Package Thermal Resistance	$R_{\theta JA}$	EV package, 4-layer PCB based on JEDEC standard JESD51-5	27	°C/W

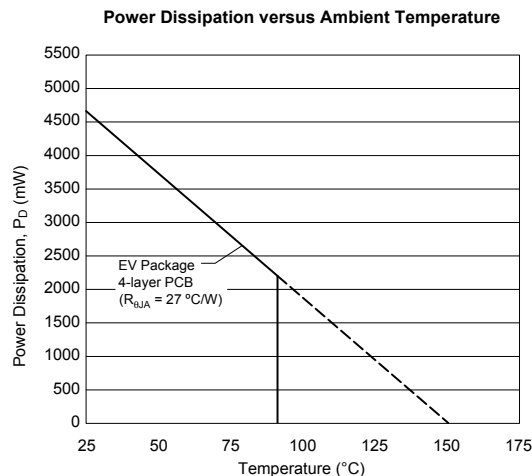

FUNCTIONAL BLOCK DIAGRAM

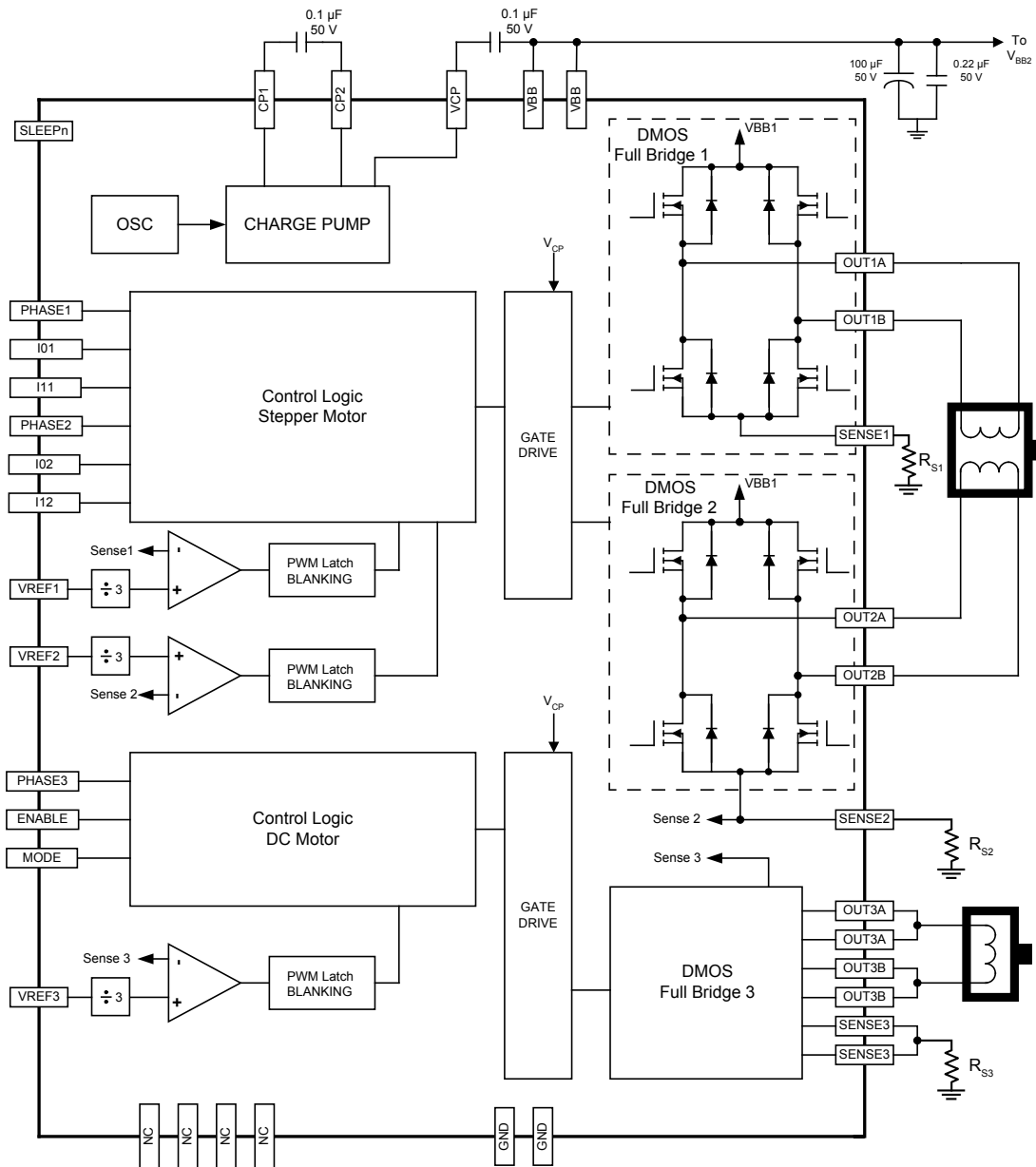

ELECTRICAL CHARACTERISTICS ^[1]: Valid at $T_A = 25^\circ\text{C}$, $V_{BB} = 40\text{ V}$, unless otherwise noted

Characteristics	Symbol	Test Conditions	Min.	Typ. ^[2]	Max.	Units
Load Supply Voltage Range	V_{BB}	Operating	8	–	40	V
Output On-Resistance (DC Motor Driver)	$R_{DS(on)DC}$	Source driver, $I_{OUT} = -1.2\text{ A}$, $T_J = 25^\circ\text{C}$	–	250	300	m Ω
		Sink driver, $I_{OUT} = 1.2\text{ A}$, $T_J = 25^\circ\text{C}$	–	240	300	m Ω
Output On-Resistance (Stepper Motor Driver)	$R_{DS(on)st}$	Source driver, $I_{OUT} = -1.2\text{ A}$, $T_J = 25^\circ\text{C}$	–	500	600	m Ω
		Sink driver, $I_{OUT} = 1.2\text{ A}$, $T_J = 25^\circ\text{C}$	–	480	600	m Ω
V_f , Outputs		$I_{OUT} = 1.2\text{ A}$	–	–	1.2	V
Output Leakage	I_{DSS}	Outputs, $V_{OUT} = 0$ to V_{BB}	–20	–	20	μA
VBB Supply Current	I_{BB}	$I_{OUT} = 0\text{ mA}$, outputs on, $f_{PWM} = 50\text{ kHz}$, duty cycle = 50%	–	–	23	mA
		Outputs off	–	12.7	15	mA
		Sleep mode	–10	< 1	10	μA
Output Driver Slew Rate	SR_{OUT}	10% to 90%	50	100	150	ns
Control Logic						
Logic Input Voltage	$V_{IN(1)}$		2	–	–	V
	$V_{IN(0)}$		–	–	0.8	V
Logic Input Current	I_{IN}	$V_{IN} = 0$ to 5 V	–20	< 1	20	μA
Input Hysteresis	V_{hys}		150	300	500	mV
Sleep Rising Threshold	$V_{SLEEPn(r)}$		2.5	2.7	2.95	V
Sleep Falling Threshold	$V_{SLEEPn(f)}$		–	2.4	–	V
Sleep Hysteresis	$V_{SLEEPn(hys)}$		250	325	450	mV
Sleep Input Current	I_{SLEEPn}		–	100	150	μA
Propagation Delay Times	t_{pd}	PWM change to source on	550	700	1000	ns
		PWM change to source off	35	–	450	ns
		PWM change to sink on	550	700	1000	ns
		PWM change to sink off	35	–	450	ns
Crossover Delay	t_{CD}		250	425	1000	ns
Blank Time (DC Motor Driver)	$t_{BLANKdc}$		2.5	3.2	4	μs
Blank Time (Stepper Motor Driver)	$t_{BLANKst}$		0.7	1	1.3	μs
VREFx Pin Input Voltage Range	V_{REFx}	Operating	0	–	1.5	V
VREFx Pin Reference Input Current	I_{REF}	$V_{REF} = 1.5\text{ V}$	–	–	± 1	μA
Current Trip-Level Error ^[3]	V_{ERR}	$V_{REF} = 1.5\text{ V}$, phase current = 100%	–5	–	5	%
		$V_{REF} = 1.5\text{ V}$, phase current = 67%	–5	–	5	%
		$V_{REF} = 1.5\text{ V}$, phase current = 33%	–15	–	15	%

Continued on the next page...

ELECTRICAL CHARACTERISTICS ^[1] (continued): Valid at $T_A = 25^\circ\text{C}$, $V_{BB} = 40\text{ V}$, unless otherwise noted

Characteristics	Symbol	Test Conditions	Min.	Typ. ^[2]	Max.	Units
Protection Circuits						
VBB UVLO Threshold	$V_{UV(VBB)}$	V_{BB} rising	7.3	7.6	7.9	V
VBB Hysteresis	$V_{UV(VBB)hys}$		400	500	600	mV
Overcurrent Protection Threshold	$I_{OVP(STEP)}$	Stepper driver	1.6	–	–	A
	$I_{OVP(DC)}$	DC driver	3.2	–	–	A
Thermal Shutdown Temperature	T_{JTSD}		155	165	175	$^\circ\text{C}$
Thermal Shutdown Hysteresis	$T_{JTSDhys}$		–	15	–	$^\circ\text{C}$

^[1] For input and output current specifications, negative current is defined as coming out of (sourcing) the specified device pin.

^[2] Typical data are for initial design estimations only, and assume optimum manufacturing and application conditions. Performance may vary for individual units, within the specified maximum and minimum limits.

^[3] $V_{ERR} = [(V_{REF} / 3) - V_{SENSE}] / (V_{REF} / 3)$.

DC Control Logic

PHASE	ENABLE	MODE	$3 \times V_S > V_{REF}$	OUTA	OUTB	Function
1	1	1	false	H	L	Forward (slow decay SR)
1	1	0	false	H	L	Forward (fast decay SR)
0	1	1	false	L	H	Reverse (slow decay SR)
0	1	0	false	L	H	Reverse (fast decay SR)
X	0	1	X	L	L	Brake (slow decay SR)
1	0	0	X	L	H	Fast decay SR*
0	0	0	X	H	L	Fast decay SR*
X	1	1	true	L	L	OCL chop / slow decay SR
1	1	0	true	L	H	OCL chop / fast decay SR*
0	1	0	true	H	L	OCL chop / fast decay SR*

* To prevent reversal of current during fast decay SR – the outputs will go to the high-impedance state as the current gets near zero.

FUNCTIONAL DESCRIPTION

Device Operation

The A5989 is designed to operate one DC motor and one bipolar stepper motor. The currents in each of the full bridges, all N-channel DMOS, are regulated with fixed off-time pulse-width-modulated (PWM) control circuitry. The peak current in each full bridge is set by the value of an external current sense resistor, R_{Sx} , and a reference voltage, V_{REFx} .

Internal PWM Current Control

Each full-bridge is controlled by a fixed off-time PWM current control circuit that limits the load current to a user-specified value, I_{TRIP} . Initially, a diagonal pair of source and sink DMOS outputs are enabled and current flows through the motor winding and R_{Sx} . When the voltage across the current sense resistor equals the voltage on the V_{REFx} pin, the current sense comparator resets the PWM latch, which turns off the source driver.

The maximum value of current limiting is set by the selection of R_S and the voltage at the V_{REF} input with a transconductance function approximated by:

$$I_{TripMax} = V_{REF} / (3 \times R_S)$$

The stepper motor outputs will define each current step as a percentage of the maximum current, $I_{TripMax}$. The actual current at each step I_{Trip} is approximated by:

$$I_{Trip} = (\% I_{TripMax} / 100) I_{TripMax}$$

where $\% I_{TripMax}$ is given in the Step Sequencing table.

Note: It is critical to ensure that the maximum rating of ± 500 mV on each $SENSEx$ pin is not exceeded.

Fixed Off-Time

The internal PWM current control circuitry uses a one-shot circuit to control the time the drivers remain off. The one-shot off-time, t_{off} , is internally set to 30 μ s.

Blanking

This function blanks the output of the current sense comparator when the outputs are switched by the internal current control circuitry. The comparator output is blanked to prevent false detections of overcurrent conditions, due to reverse recovery currents of the clamp diodes, or to switching transients related to the capacitance of the load. DC motors require more blank time than stepper motors. The stepper driver blank time, $t_{BLANKst}$, is approximately 1 μ s. The DC driver blank time, $t_{BLANKdc}$, is approximately 3 μ s.

Control Logic

Stepper motor communication is implemented via industry standard I1, I0, and PHASE interface. This communication logic allows for full-, half-, and quarter-step modes. Each bridge also has an independent V_{REF} input so higher resolution step modes can be programmed by dynamically changing the voltage on the corresponding V_{REFx} pin. The DC motor is controlled using standard PHASE, ENABLE communication. Fast or slow current decay during the off-time is selected via the MODE pin.

Charge Pump (CP1 and CP2)

The charge pump is used to generate a gate supply greater than V_{BB} in order to drive the source-side DMOS gates. A 0.1 μ F ceramic capacitor should be connected between CP1 and CP2 for pumping purposes. A 0.1 μ F ceramic capacitor is required between VCP and V_{BBx} to act as a reservoir to operate the high-side DMOS devices.

Sleep Mode

To minimize power consumption when not in use, the A5989 can be put into Sleep Mode by bringing the SLEEPn pin low. Sleep Mode disables much of the internal circuitry, including the charge pump.

Overcurrent Protection

An overcurrent monitor protects the A5989 from damage due to output shorts. If a short is detected, the A5989 latches the fault and disables the outputs. The latched fault can only be cleared by cycling the power to V_{BB} or by putting the device in Sleep Mode. During OCP events, Absolute Maximum Ratings may be exceeded for a short period of time before outputs are latched off.

Shutdown

In the event of a fault (excessive junction temperature, or low voltage on VCP), the outputs of the device are disabled until the fault condition is removed. At power-up, the undervoltage lock-out (UVLO) circuit disables the drivers.

Synchronous Rectification

When a PWM off cycle is triggered by an internal fixed off-time cycle, load current will recirculate. The A5989 synchronous rectification feature will turn on the appropriate MOSFETs during the current decay. This effectively shorts the body diode with the low $R_{DS(on)}$ driver. This significantly lowers power dissipation. When a zero current level is detected, synchronous rectification is turned off to prevent reversal of the load current.

Mixed Decay Operation

The stepper driver operates in mixed decay mode. Referring to Figure 2, as the trip point is reached, the device goes into fast decay mode for 30.1% of the fixed off-time period. After this fast decay portion, t_{FD} , the device switches to slow decay mode for the remainder of the off-time. The DC driver decay mode is determined by the MODE pin. During transitions from fast decay to slow decay, the drivers are forced off for approximately 600 ns. This feature is added to prevent shoot-through in the bridge. As shown in Figure 2, during this “dead time” portion, synchronous rectification is not active, and the device operates in fast decay and slow decay only.

MODE

Control input MODE is used to toggle between fast decay mode and slow decay mode for the DC driver. A logic high puts the device in slow decay mode. Synchronous rectification is always enabled when ENABLE is low.

Braking

Driving the device in slow decay mode via the MODE pin and applying an ENABLE chop command implements the Braking function. Because it is possible to drive current in both directions through the DMOS switches, this configuration effectively shorts the motor-generated BEMF as long as the ENABLE chop mode is asserted. The maximum current can be approximated by V_{BEMF}/R_L . Care should be taken to ensure that the maximum ratings of the device are not exceeded in worst-case braking situations: high speed and high inertia loads.

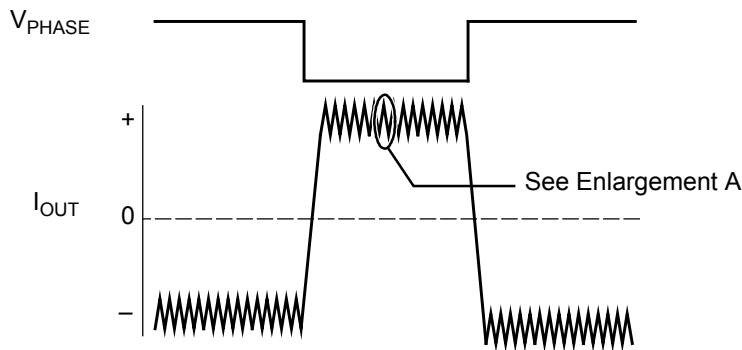

Enlargement A

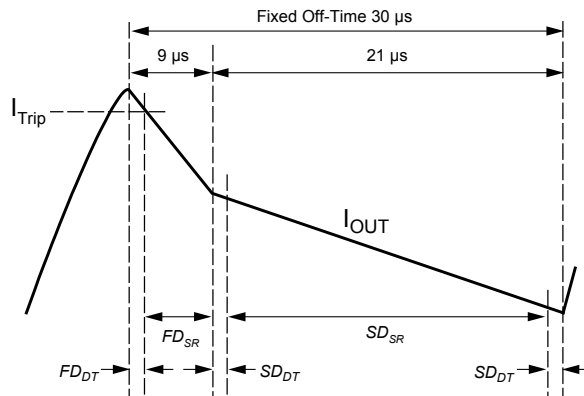

Figure 2: Mixed Decay Mode Operation

STEP SEQUENCING DIAGRAMS

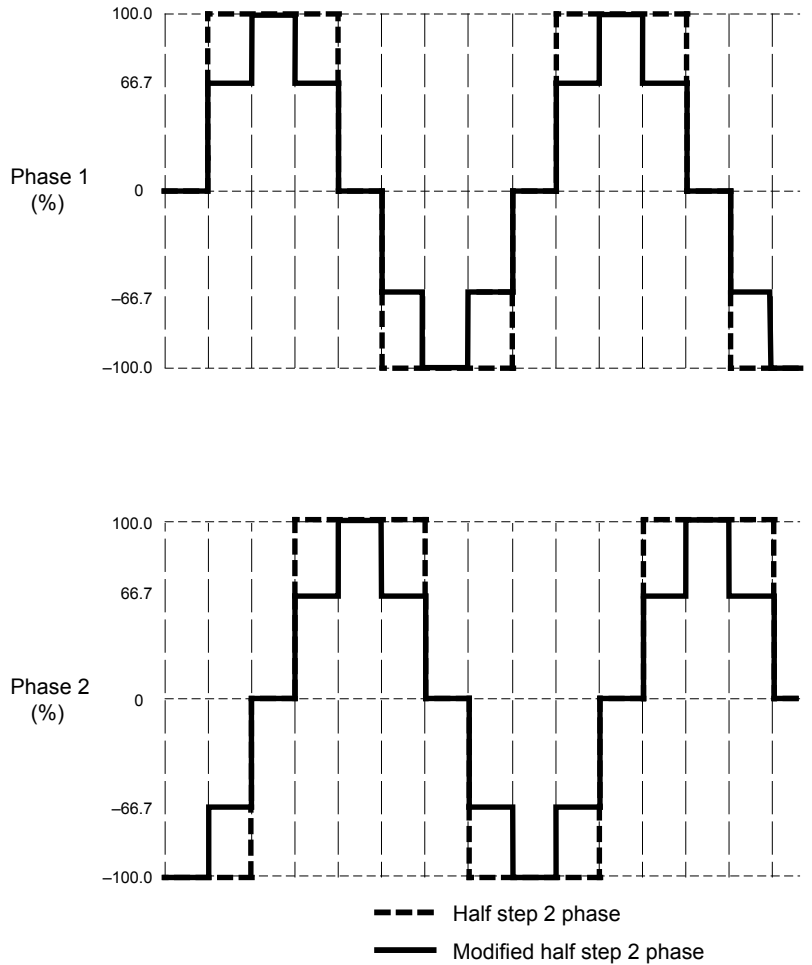
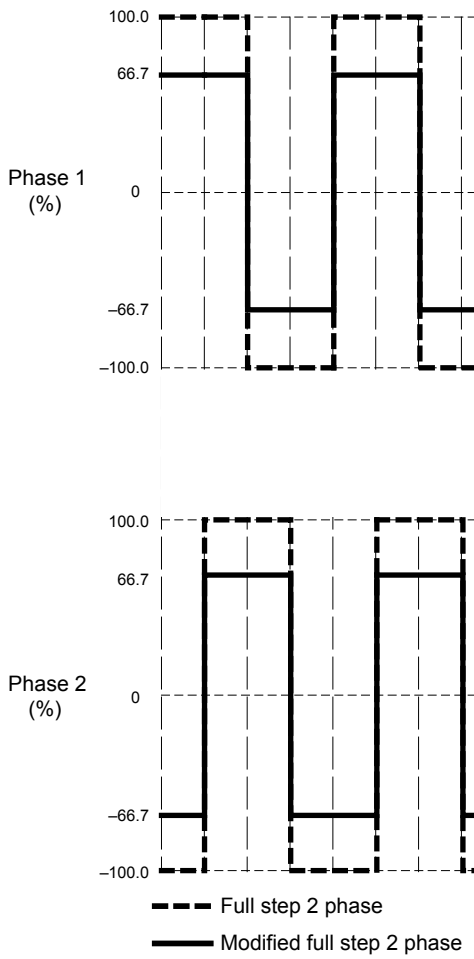

Figure 3: Step Sequencing for Full-Step Increments

Figure 4: Step Sequencing for Half-Step Increments

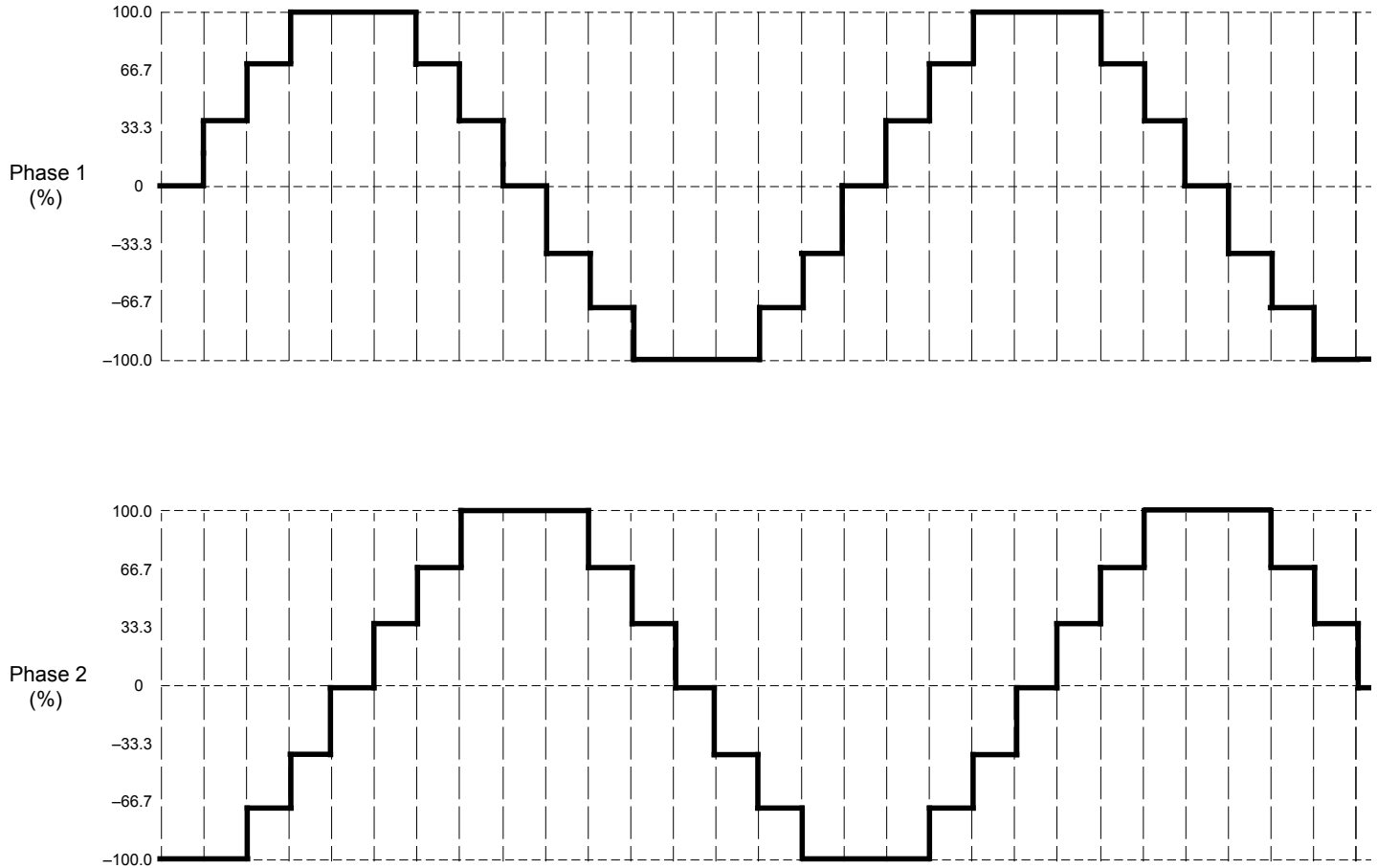

Figure 5: Decay Modes for Quarter-Step Increments

Step Sequencing Settings

Full	1/2	1/4	Phase 1 (%I _{TripMax})	I0x	I1x	PHASE	Phase 2 (%I _{TripMax})	I0x	I1x	PHASE
	1	1	0	H	H	X	100	L	L	0
		2	33	L	H	1	100	L	L	0
1	2	3	100/66*	L/H*	L	1	100/66*	L/H*	L	0
		4	100	L	L	1	33	L	H	0
	3	5	100	L	L	1	0	H	H	X
		6	100	L	L	1	33	L	H	1
2	4	7	100/66*	L/H*	L	1	100/66*	L/H*	L	1
		8	33	L	H	1	100	L	L	1
	5	9	0	H	H	X	100	L	L	1
		10	33	L	H	0	100	L	L	1
3	6	11	100/66*	L/H*	L	0	100/66*	L/H*	L	1
		12	100	L	L	0	33	L	H	1
	7	13	100	L	L	0	0	H	H	X
		14	100	L	L	0	33	L	H	0
4	8	15	100/66*	L/H*	L	0	100/66*	L/H*	L	0
		16	33	L	H	0	100	L	L	0

*Denotes modified step mode

LOGIC TIMING DIAGRAM, DC DRIVER

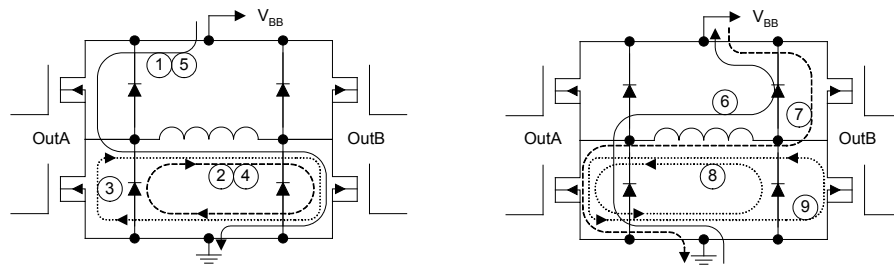
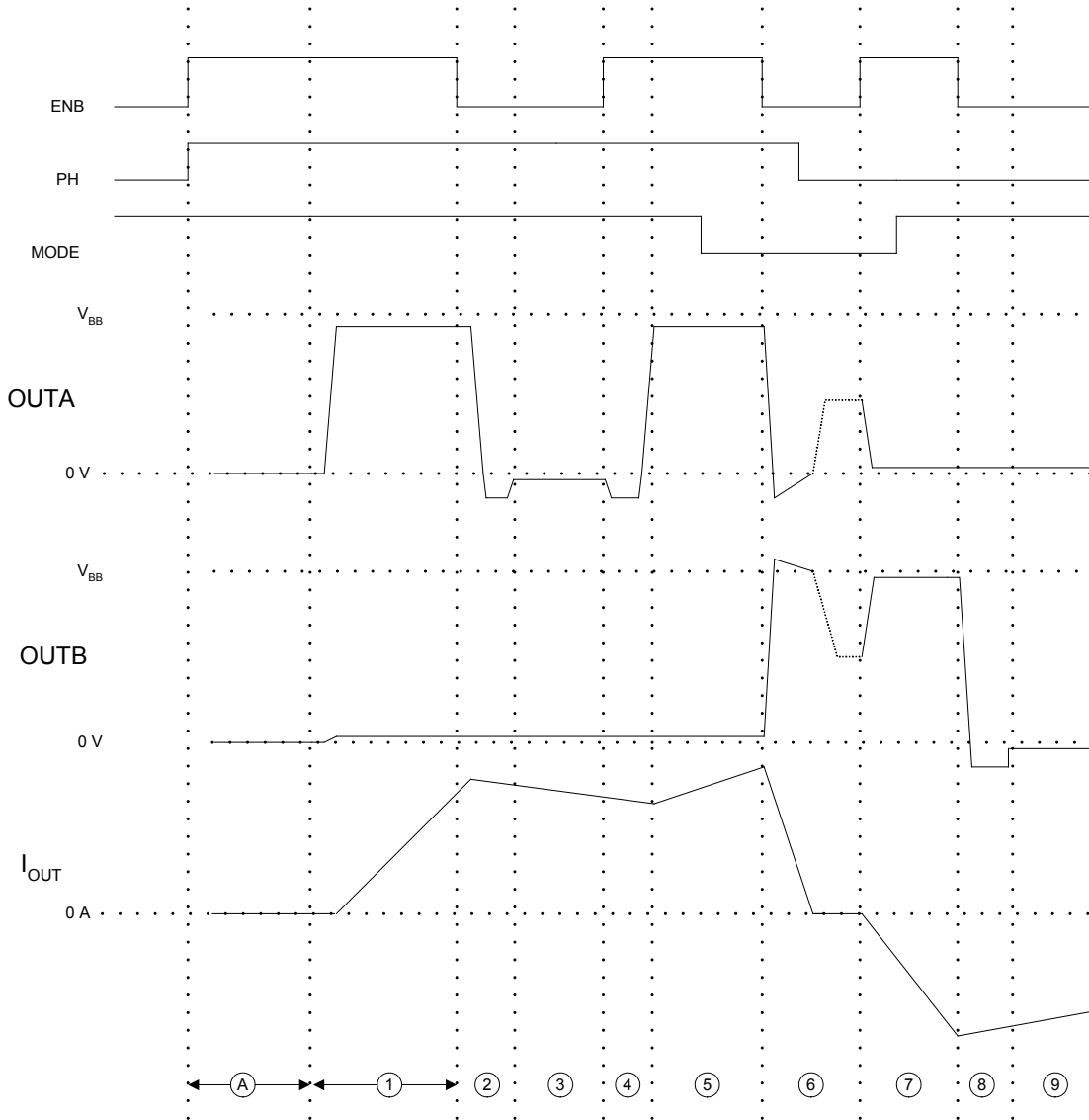

(A) Charge Pump and VREG Power-up Delay ($\approx 200 \mu\text{s}$)

APPLICATIONS INFORMATION

Motor Configurations

For applications that require either dual DC or dual stepper motors, Allegro offers the A5988 and A5995. Both devices are offered in a 36 pin QFN package. Refer to the Allegro website for datasheets and further information for the devices.

Layout

The printed circuit board should use a heavy groundplane. For optimum electrical and thermal performance, the A5989 must be soldered directly onto the board. On the underside of the A5989 package is an exposed pad, which provides a path for enhanced thermal dissipation. The thermal pad should be soldered directly to an exposed surface on the PCB. Thermal vias are used to transfer heat to other layers of the PCB.

Grounding

In order to minimize the effects of ground bounce and offset issues, it is important to have a low-impedance single-point ground, known as a *star ground*, located very close to the device. By making the connection between the exposed thermal pad and the groundplane directly under the A5989, that area becomes an ideal location for a star ground point.

A low-impedance ground will prevent ground bounce during high-current operation and ensure that the supply voltage remains

stable at the input terminal. The recommended PCB layout shown in the diagram below, illustrates how to create a star ground under the device, to serve both as low-impedance ground point and thermal path.

The two input capacitors should be placed in parallel, and as close to the device supply pins as possible. The ceramic capacitor should be closer to the pins than the bulk capacitor. This is necessary because the ceramic capacitor will be responsible for delivering the high-frequency current components.

Sense Pins

The sense resistors, RSx, should have a very low-impedance path to ground, because they must carry a large current while supporting very accurate voltage measurements by the current sense comparators. Long ground traces will cause additional voltage drops, adversely affecting the ability of the comparators to accurately measure the current in the windings. As shown in the layout below, the SENSEx pins have very short traces to the RSx resistors and very thick, low-impedance traces directly to the star ground underneath the device. If possible, there should be no other components on the sense circuits.

Note: When selecting a value for the sense resistors, be sure not to exceed the maximum voltage on the SENSEx pins of ± 500 mV.

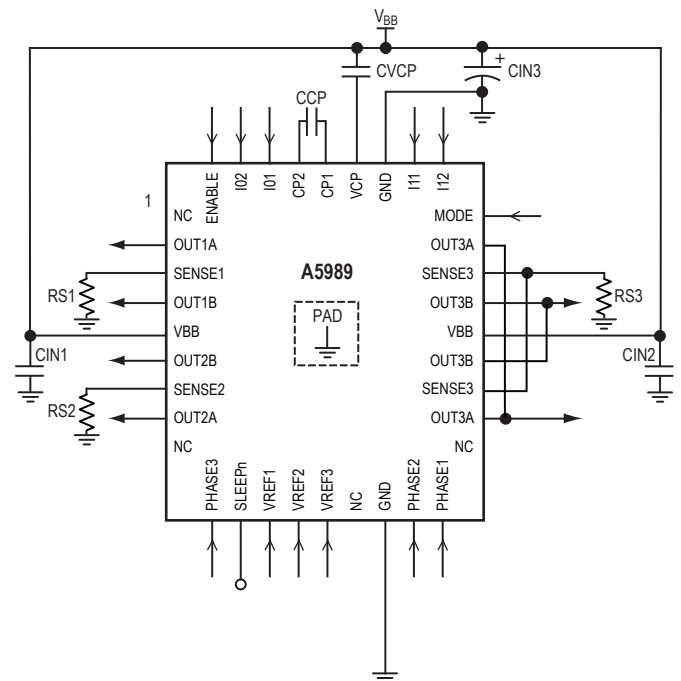
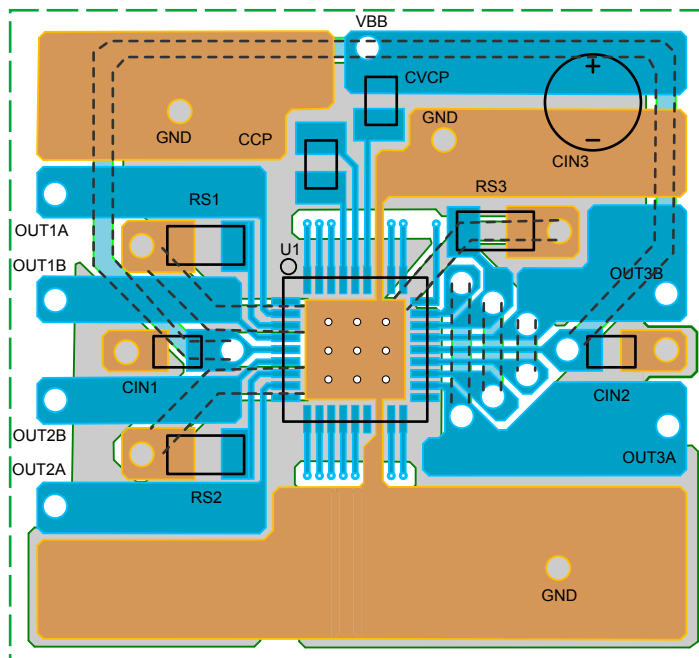
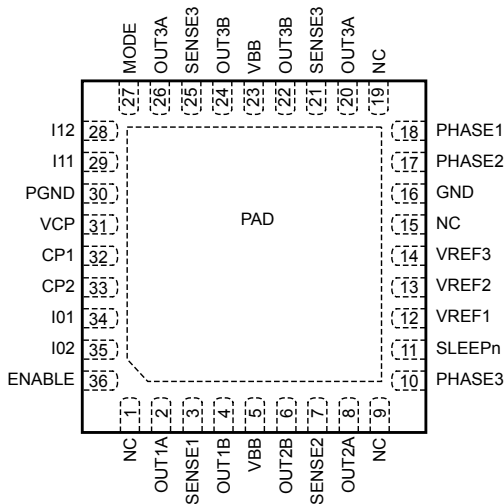

Figure 6: Printed circuit board layout with typical application circuit, shown at right. The copper area directly under the A5989 (U1) is soldered to the exposed thermal pad on the underside of the device. The thermal vias serve also as electrical vias, connecting it to the ground plane on the other side of the PCB, so the two copper areas together form the star ground.

Pinout Diagram



Terminal List Table

Number	Name	Description
1	NC	No Connect
2	OUT1A	DMOS Full Bridge 1 Output A
3	SENSE1	Sense Resistor Terminal for Bridge 1
4	OUT1B	DMOS Full Bridge 1 Output B
5	VBB	Load Supply Voltage
6	OUT2B	DMOS Full Bridge 2 Output B
7	SENSE2	Sense Resistor Terminal for Bridge 2
8	OUT2A	DMOS Full Bridge 2 Output A
9	NC	No Connect
10	PHASE3	Control Input
11	SLEEPn	Active-Low Sleep Mode Input
12	VREF1	Analog Input
13	VREF2	Analog Input
14	VREF3	Analog Input
15	NC	No Connect
16	PGND	Power Ground
17	PHASE2	Control Input
18	PHASE1	Control Input
19	NC	No Connect
20	OUT3A	DMOS Full Bridge 3 Output A
21	SENSE3	Sense Resistor Terminal for Bridge 3
22	OUT3B	DMOS Full Bridge 3 Output B
23	VBB	Load Supply Voltage
24	OUT3B	DMOS Full Bridge 3 Output A
25	SENSE3	Sense Resistor Terminal for Bridge 3
26	OUT3A	DMOS Full Bridge 3 Output B
27	MODE	Control Input
28	I12	Control Input
29	I11	Control Input
30	GND	Ground
31	VCP	Reservoir Capacitor Terminal
32	CP1	Charge Pump Capacitor Terminal
33	CP2	Charge Pump Capacitor Terminal
34	I01	Control Input
35	I02	Control Input
36	ENABLE	Control Input
-	PAD	Exposed pad for enhanced thermal performance. Should be soldered to the PCB

PACKAGE OUTLINE DRAWING

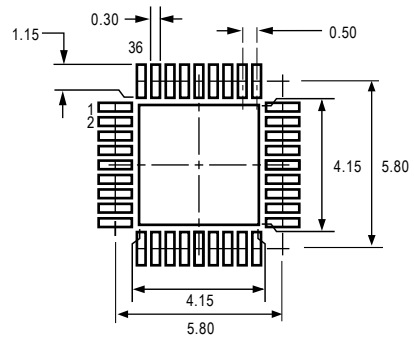
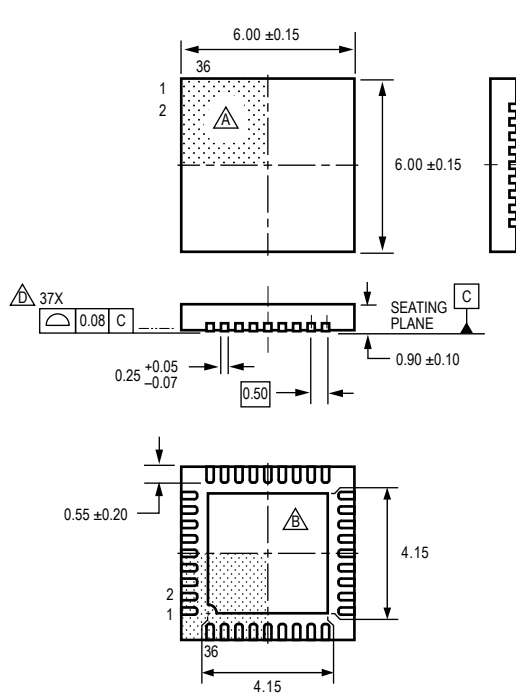

All dimensions nominal, not for tooling use
 (reference JEDEC MO-220V/JD-3, except pin count)
 Dimensions in millimeters
 Exact case and lead configuration at supplier discretion within limits shown

- Terminal #1 mark area
- Exposed thermal pad (reference only, terminal #1 identifier appearance at supplier discretion)
- Reference land pattern layout (reference IPC7351 QFN50P600X600X100-37V1M); All pads a minimum of 0.20 mm from all adjacent pads; adjust as necessary to meet application process requirements and PCB layout tolerances; when mounting on a multilayer PCB, thermal vias at the exposed thermal pad land can improve thermal dissipation (reference EIA/JEDEC Standard JESD51-5)
- Coplanarity includes exposed thermal pad and terminals

EV Package, 36-Pin QFN with Exposed Thermal Pad

Revision History

Number	Date	Description
–	June 20, 2016	Initial release
1	July 29, 2016	Updated Selection Guide table
2	November 29, 2017	Updated Step Sequences Settings table (page 9)
3	January 29, 2019	Minor editorial updates

Copyright ©2019, Allegro MicroSystems, LLC

Allegro MicroSystems, LLC reserves the right to make, from time to time, such departures from the detail specifications as may be required to permit improvements in the performance, reliability, or manufacturability of its products. Before placing an order, the user is cautioned to verify that the information being relied upon is current.

Allegro's products are not to be used in any devices or systems, including but not limited to life support devices or systems, in which a failure of Allegro's product can reasonably be expected to cause bodily harm.

The information included herein is believed to be accurate and reliable. However, Allegro MicroSystems, LLC assumes no responsibility for its use; nor for any infringement of patents or other rights of third parties which may result from its use.

Copies of this document are considered uncontrolled documents.

For the latest version of this document, visit our website:

www.allegromicro.com